

Unique Fluid Power Solution combines low energy consumption with high precision control!

Electro-Hydraulic hybrid system

ECO SERVO

Kawasaki Heavy Industries, Ltd.

Precision Machinery Business Division

<http://www.khi.co.jp/kpm/>

Tokyo Head Office

1-14-5 Kaigan, Minato-ku, Tokyo 105-8315, Japan
Phone +81-3-3435-6862 Fax. +81-3-3435-2023

Kobe Head Office

Kobe Crystal Tower, 1-3 Higashikawasaki-cho 1-chome, Chuo-ku, Kobe 650-8680, Japan
Phone +81-78-360-8607 Fax. +81-78-360-8609

Nishi-kobe Works

234, Matsumoto, Hasetani-cho, Nishi-ku, Kobe 651-2239, Japan
Phone +81-78-991-1160 Fax. +81-78-991-3186

OVERSEAS SUBSIDIARIES

Kawasaki Precision Machinery (UK) Ltd.

Ernesettle Lane, Ernesettle, Plymouth, Devon, PL5 2SA United Kingdom
Phone +44-1752-364394 Fax. +44-1752-364816
<http://www.kpm-eu.com>

Kawasaki Precision Machinery (U.S.A.), Inc.

3838 Broadmoor Avenue S.E. Grand Rapids, Michigan 49512, U.S.A.
Phone +1-616-975-3100 Fax. +1-616-975-3103
<http://www.kpm-usa.com>

Kawasaki Precision Machinery (Suzhou) Ltd.

668 JianLin Rd, New District, Suzhou, 215151 China
Phone +86-512-6616-0365 Fax. +86-512-6616-0366

Kawasaki Precision Machinery Trading (Shanghai) Co., Ltd.

17th Floor (Room 1701), The Headquarters Building, No168, XiZang Road (M), Huangpu District, Shanghai, 200001, China
Phone +86-21-3366-3800 Fax. +86-21-3366-3808

Kawasaki Chunhui Precision Machinery (Zhejiang) Ltd.

No.200 Yasha Road Shangyu Economic Development Zone, Shansyu, Zhejiang, 312300, China
Phone +86-575-8215-6999 Fax. +86-575-8215-8699

Flutek, Ltd.

98 GIL 6, Gongdan-Ro, Seongsan-Ku, Changwon-Si, Kyungnam, 51567, Korea
Phone +82-55-210-5900 Fax. +82-55-286-5557

Wipro Kawasaki Precision Machinery Private Limited

No. 15, Sy. No. 35 & 37, Kumbalgodu Industrial Area, Kumbalgodu Village, Kengeri Hobli, Bangalore, - 560074, India

Materials and specifications are subject to change without manufacturer's obligation.



△
QR code
Precision Machinery
Business Division

Cat. No. KPM2041 Mar. '21 ©
Printed in Japan

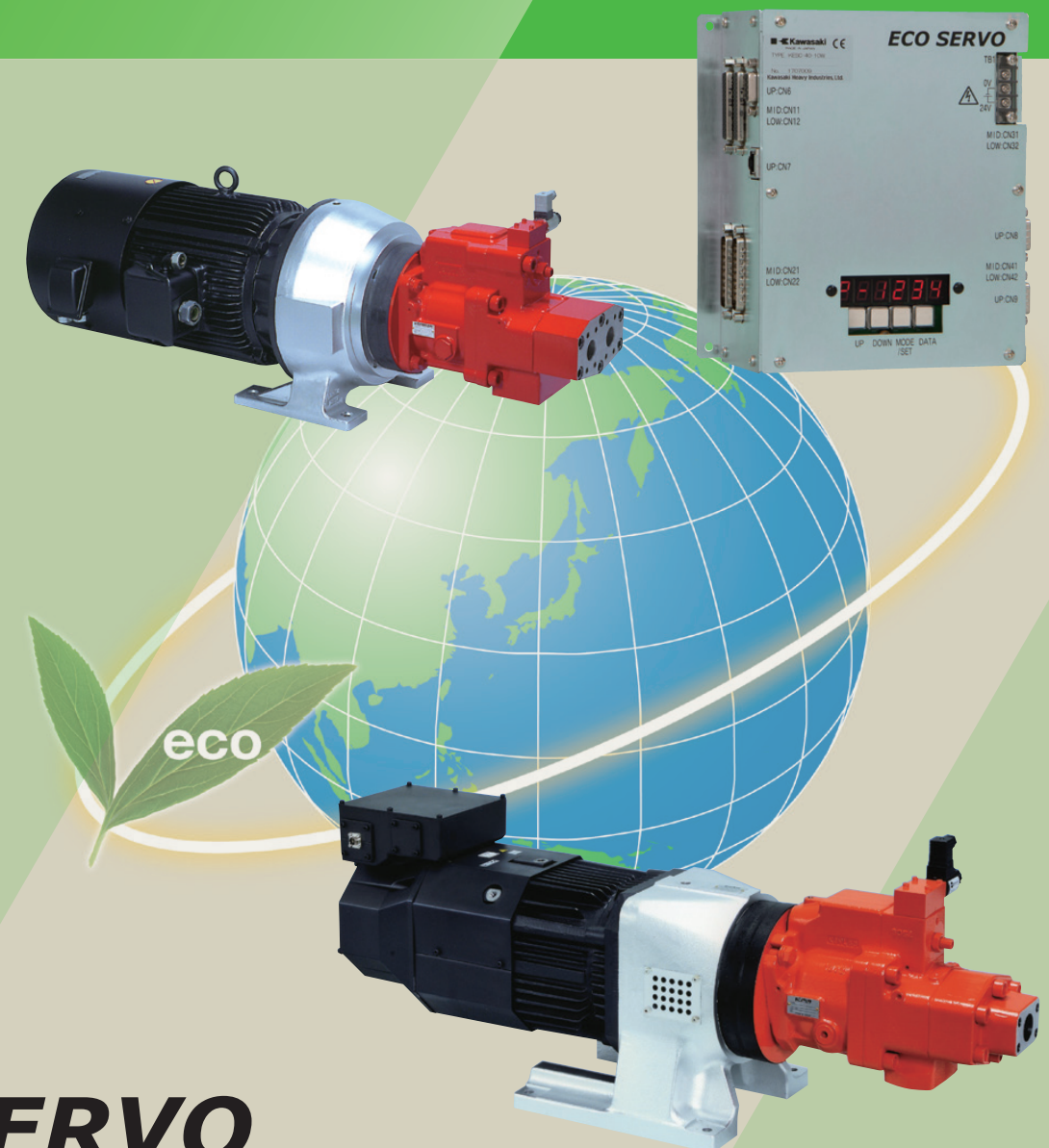

ECO SERVO

● When you are addressing engineering challenges such as:

<Hydraulic Drive System>



- You intend to proceed with energy saving programs.
- You want to improve controllability and control functionality.
- You need a simpler maintenance practice.
- You wish to minimize noise and vibration on the machinery. etc.

<Electric Drive System>



- The initial cost is high.
- The service life of the ball-screw is too short.
- The maintenance work is too labor-intensive.
- The drive mechanism requires too much space. etc.

ECO SERVO
offers a solution optimized for your problem!

ECO SERVO system is an optimal choice for renovating an existing hydraulic system!

Higher degree of energy saving is achieved through decreased power consumption and power regeneration!

- ECO SERVO helps minimize power consumption while actuators are at a standstill and/or hydraulic pressure is held.
- Dramatic energy saving is achieved through operation with the minimum necessary power that contributes to reduction in power consumption; as well as through reduction in the pressure loss on circuit.
- When used in conjunction with a power regenerative system, ECO SERVO system allows the braking energy from a load side to be reused.

Ideal in improving characteristics of hydraulic systems!

- Through control of an electric motor speed, the hydraulic system can have controllability as well as electric drive system.
- Effect of variation in hydraulic fluid temperature is minimized, and this fact leads to improved repeatability.
- Loss in the pressure on hydraulic circuit is decreased. As a result, a higher hydraulic output is obtained from a given input power.

Unique mechanism helps achieve lower noise!

- Use of a resilient support and high-rigidity bracket for the pump dampens transmission of vibration from the pump.
- By controlling the electric motor speed, the running noise on the hydraulic pump running at a lower speed is minimized.

Cost reduction is achieved, compared with electric drive systems!

- One electro-hydraulic hybrid system can drive a plurality of actuators at a time. Therefore, the number of electric motors can be decreased. (Depending on the nature of the entire system, the number of necessary electric motors may not be decreased.)
- When used in conjunction with a variable displacement pump, ECO SERVO helps decrease the necessary capacities of the electric motors as well as the necessary driving torque.

Simple configuration contributes to improved maintainability!

- Unlike electrically driven systems, you are spared the replacement works of ball-screw and/or maintenance for grease.
- Since the hydraulic circuit is simple, the number of components that require time-consuming adjustment works can be decreased.
- Unlike servo-valve system, strict maintenance works of hydraulic fluid are not necessary.

Reduced space needed for the entire system!

- The hydraulic power transmission system enables flexible layout design. This results in a compact design for the entire system.
- The decreased loss of energy leads to less heat generation, and this allows the capacities for hydraulic fluid, fluid tank and cooler to be much smaller.

Energy saving

Improved controllability and control functionality

Lower noise

Reduced cost

Improved maintainability

Compact configuration



Electro-Hydraulic hybrid system

<KAWASAKI's unique electro-hydraulic hybrid system defined>

- The electro-hydraulic hybrid system controls the speed of the electric motor directly coupled to the hydraulic pump in accordance with the power requirement in order to control the discharge from the hydraulic pump. We call this unique system "ECO SERVO".
- This system allows the users to build a hybrid system that features advantages of both hydraulic and electric control systems.
- With ECO SERVO, the user can control hydraulic equipment while fully making use of the advantages unique to hydraulic systems with ease as if the user is handling an electric drive system.

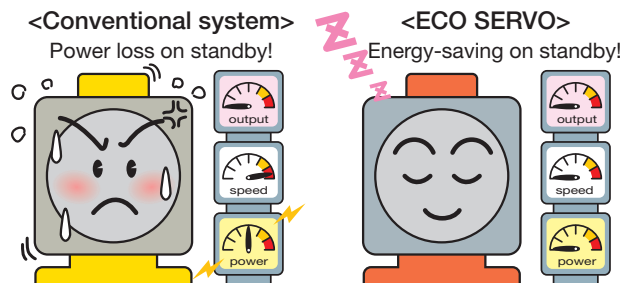

By controlling the speed of an electric motor, a hydraulic pump is run only when hydraulic power is necessary; as a result, the required power consumption is much reduced.

<Benefits of ECO SERVO>

- ECO SERVO employs the KAWASAKI piston pump K3VR, K3VL, K7VG series product that boasts good reputation for their high pressure rating, high capacity and high efficiency. Peak pressure: 35 MPa, Max. discharge: 600 L/min (pump displacement: 500 cm³)
- Applicable to both open and closed circuits
ECO SERVO series products include not only the standard pump intended for open circuits but also special pumps (with suction valve) intended for reversible high-pressure and closed circuits. ECO SERVO can be applied to a diversity of hydraulic circuits.
- Variable displacement pump is employed.
Through use of a variable displacement pump that is capable of two displacement settings, the necessary drive torque can be lower and the necessary motor capacity can be smaller.
- Applicable to both servo drive and inverter drive.

Comparison with Conventional Hydraulic Circuits

Examples of ordinary open circuit

Incorporation of ECO SERVO contributes to elimination of components otherwise needed on conventional hydraulic circuits—for example, proportional pressure control valves and flow control valves as well as servo regulators and pilot pumps for variable displacement pumps.

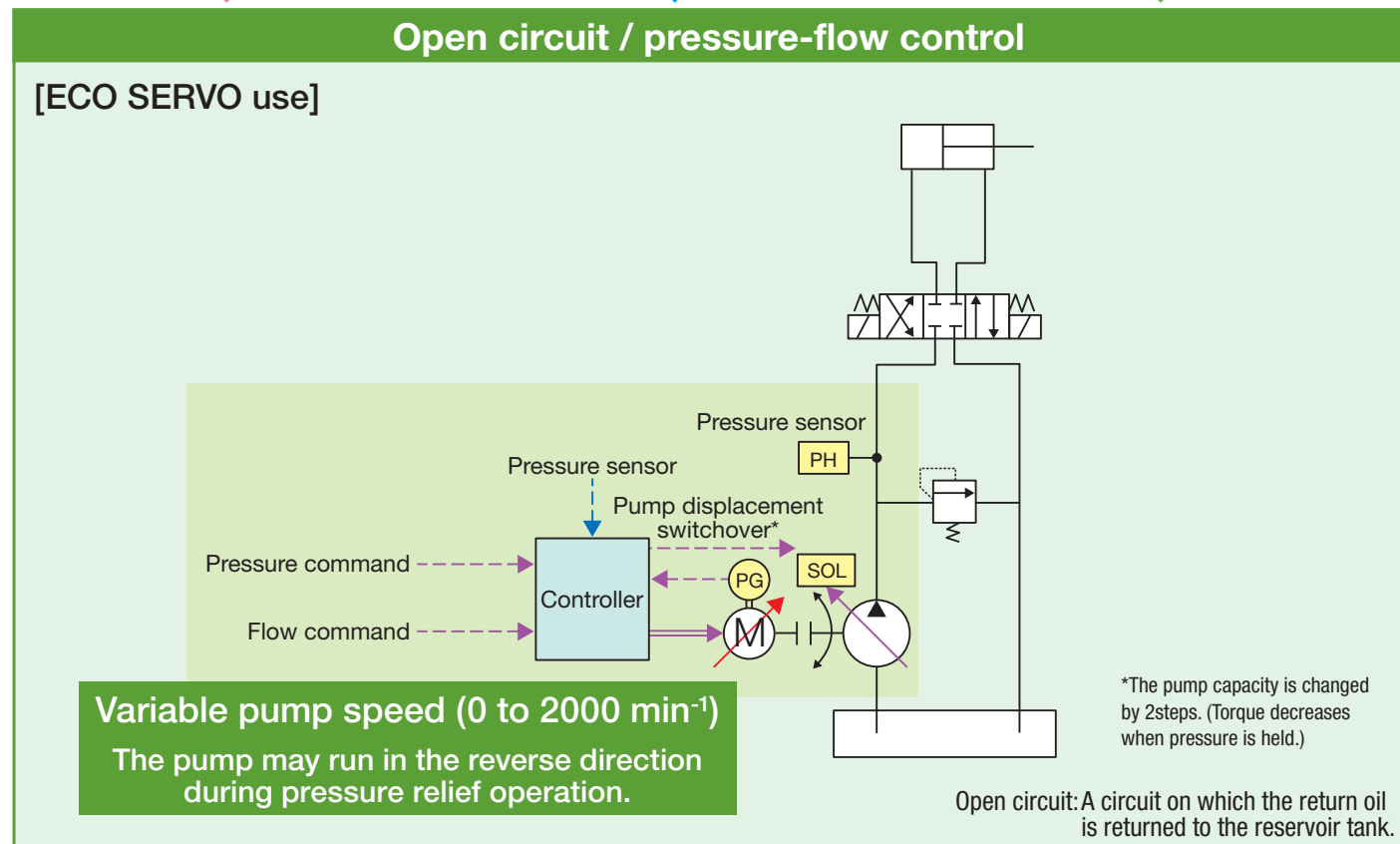
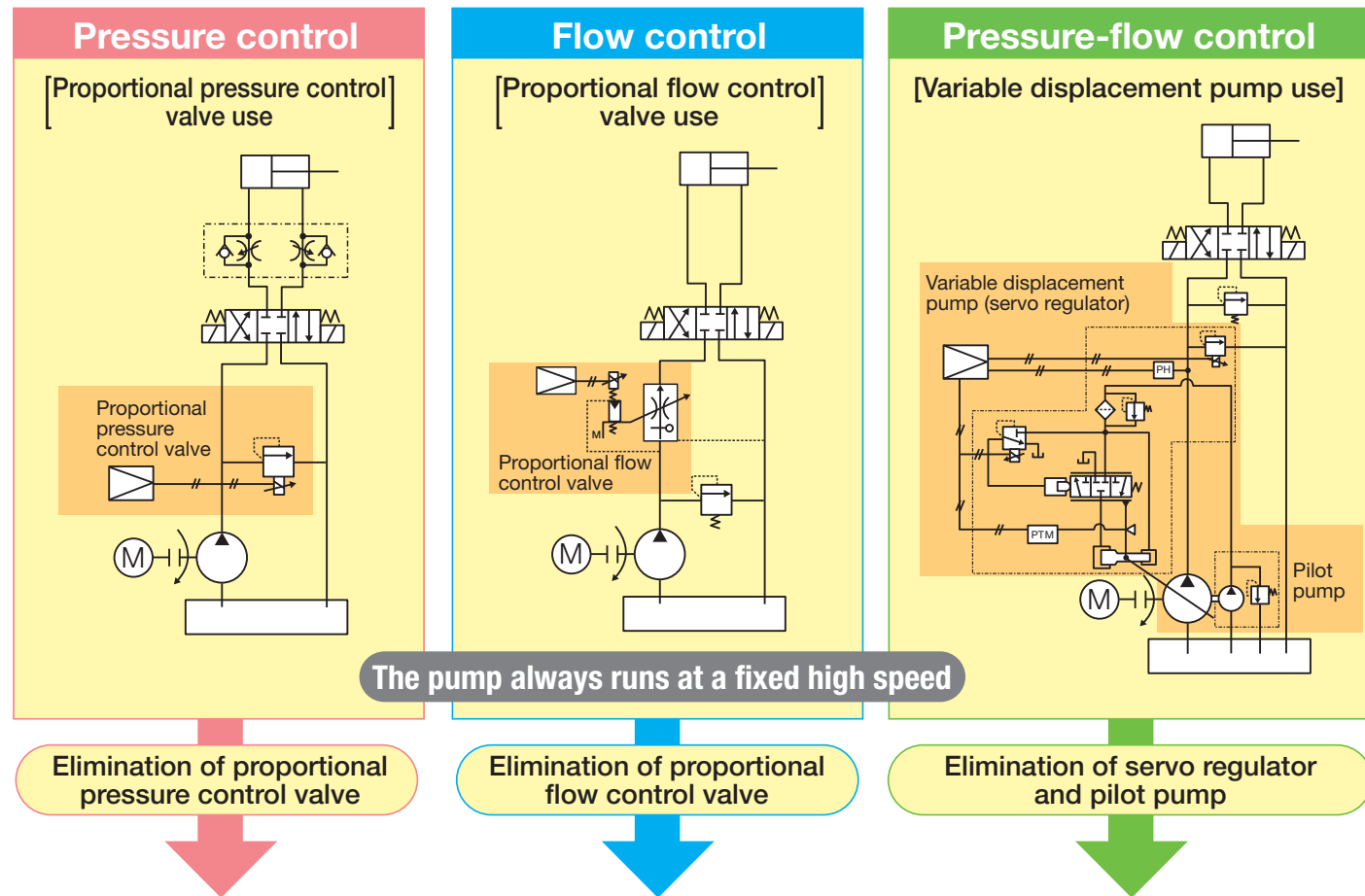

Examples of typical closed circuit for press machine

Elimination of a servo valve or servo regulator and pilot pump and other elements for the hydraulic pump leads to a unique hydraulic circuit that realizes higher output, decreased energy consumption and compact size.

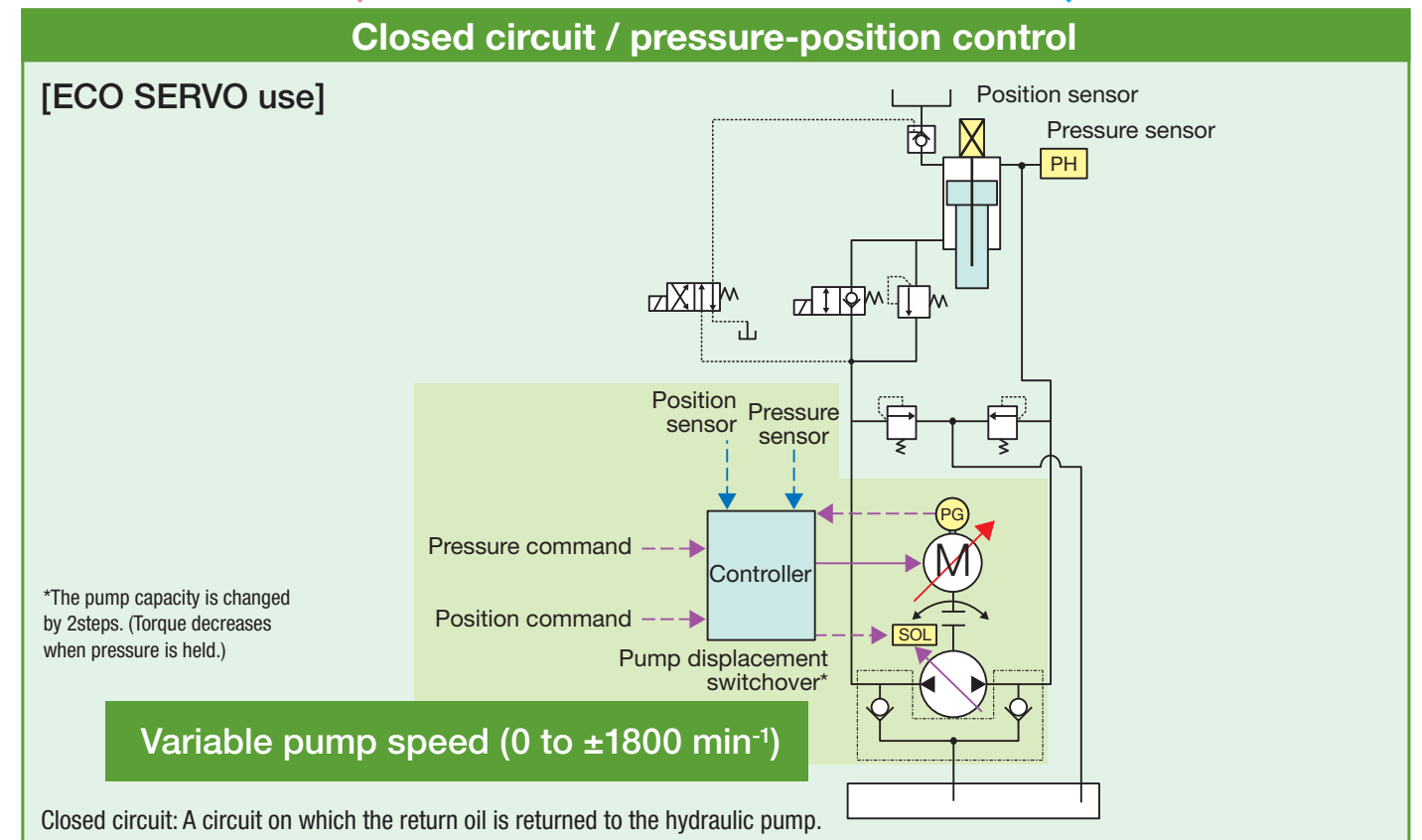
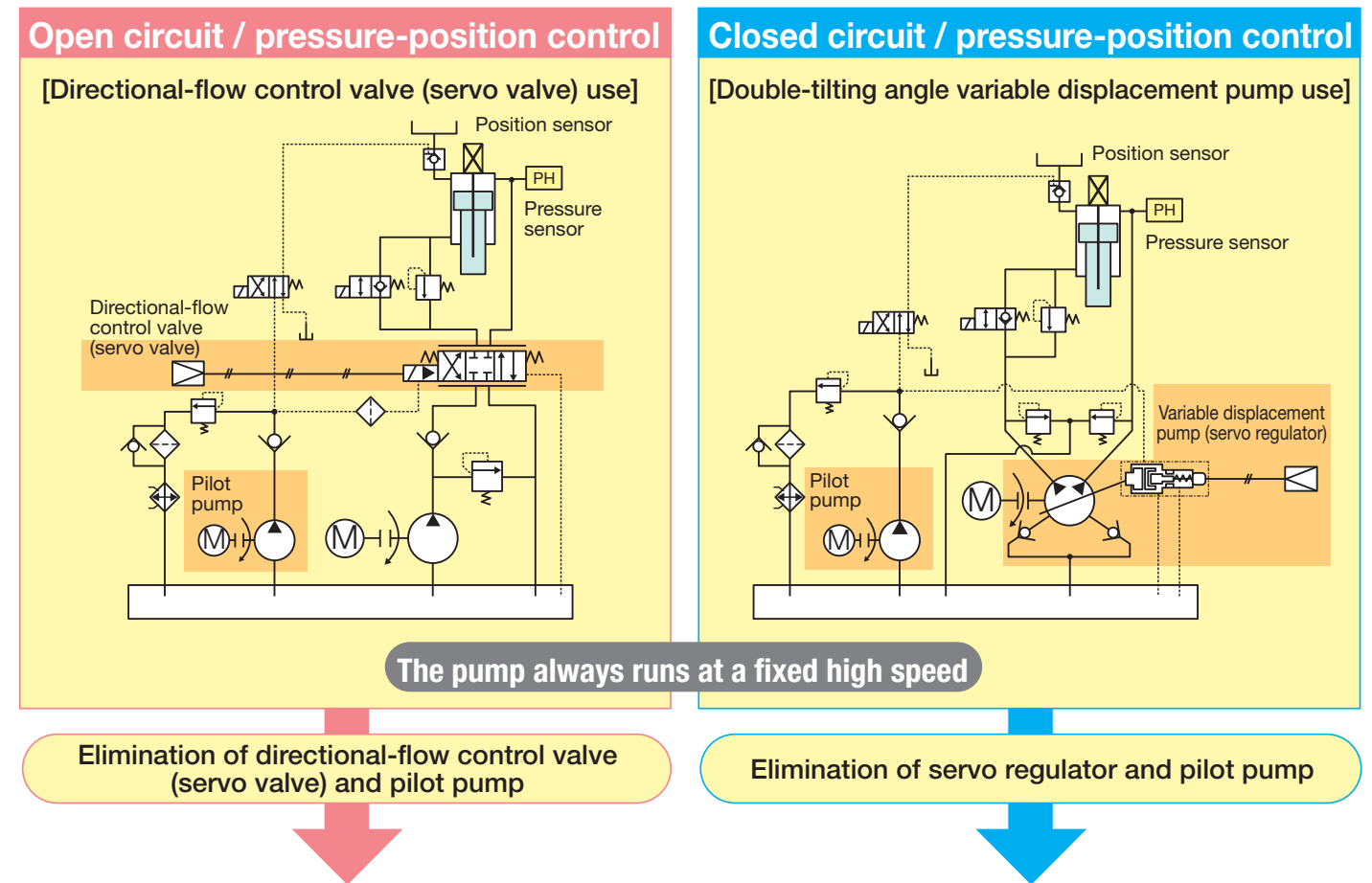

ECO SERVO: Product Lineup

The unique lineup of products can cope with requirements for a diversity of systems.

Making the most of the high performance hydraulic pumps with the capacity of high pressure, low fluctuation and high efficiency, ECO SERVO covers a wide range of displacement. ^{*1}

Pump displacement	cm ³	22	45	80	140	200	500					
Inverter drive	Motor capacity	kW	7.5	11	22	30	30	37	45	55	75	90
	Rated torque ^{*2}	N·m	47.7	70	140	191	191	235	286	350	477	572
	Max. torque ^{*3}	N·m	71.6	105	211	287	287	353	429	525	715	858
Servo drive	Motor capacity	kW	5	7	7	11	11	15	37	45	45	55
	Rated torque ^{*2}	N·m	23.9	33.4	33.4	70	70	95.5	236	286	286	350
	Max. torque ^{*3}	N·m	71.6	100	100	210	210	286	707	859	859	1,050
Pump pressure	Max. operating	MPa	32									
	Peak	MPa	35									
Max. speed ^{*4}	min ⁻¹	2,000 (for Open Circuit), 1,800 (for Closed Circuit)										
Hydraulic fluid type		Antiwear hydraulic fluid ^{*5}										
Supply voltage/frequency		200 to 230V, 380 to 480V 50/60Hz										

The pump displacement of 500 cm³ is individually available. When considering this capacity, contact Kawasaki Precision Machinery.

^{*1}: When considering other combination of pump displacement and motor capacity, contact Kawasaki Precision Machinery.
^{*2}: Rated speed of the electric motor is 1500 min⁻¹. (2000 min⁻¹ only when the servo drive is rated at 5 kW or 7 kW)
^{*3}: The max. torque values are short-time rating values. Be sure to select the appropriate servo or inverter drive such that the effective torque value for each cycle is below the corresponding rated torque.
^{*4}: The max. speed might be subject to the limit depending on various conditions such as the use conditions and operating cycle.
^{*5}: When wanting to use a hydraulic fluid not specified above, contact Kawasaki Precision Machinery for technical assistance.

< Pump unit model name >

KESP 80 C - V110 - A A - 4P - 20

<displacement>
 22 : 22 cm³ / 5.5 cm³
 45 : 45 cm³ / 11 cm³
 80 : 80 cm³ / 20 cm³
 140 : 140 cm³ / 35 cm³
 200 : 200 cm³ / 50 cm³

<Applicable electric motor>
 Inverter drive Servo drive
 V37 : 3.7kW S35 : 3.5kW
 V55 : 5.5kW S50 : 5kW
 V75 : 7.5kW S70 : 7kW
 V110 : 11kW S110 : 11kW
 V150 : 15kW S150 : 15kW
 V185 : 18.5kW S220 : 22kW
 V220 : 22kW S300 : 30kW
 V300 : 30kW S370 : 37kW
 V370 : 37kW S450 : 45kW
 V450 : 45kW S550 : 55kW
 V550 : 55kW
 V750 : 75kW
 V900 : 90kW

<Circuit configuration>
 No code : OPEN circuit
 C : CLOSED circuit

<Inverter electric motor rated speed>
 4P : 1500min⁻¹
 6P : 1000min⁻¹
 Fixed to 4P whenever any servo drive is selected.
 7 kW or lower: 2000 min⁻¹
 11 kW or higher: 1500 min⁻¹

<Solenoid valve power supply>
 A : DC24V
 B : AC115V

<Main circuit power supply>
 A : 200V 50/60Hz / 220V 60Hz
 B : 400V 50/60Hz / 440V 60Hz

< Hydraulic controller model name >

KESC- 40 - 10 S : Position-pressure control

Hardware ver. Series ver. Control target
 S : 1axis
 W : 2axes

KESC- 31 PQ - 10 : Pressure-flow control

^{*6}: For detailed information about the constituent components of the above-mentioned pump unit types, refer to the System Configuration section in the next page.

Possible System Configurations

Capable of applications to various systems

Open circuit configuration

<Hydraulic controller: pressure-flow control>
 When the pressure does not increase to the commanded level when the entire system is under a light load, the entire system is controlled based on the flow command.

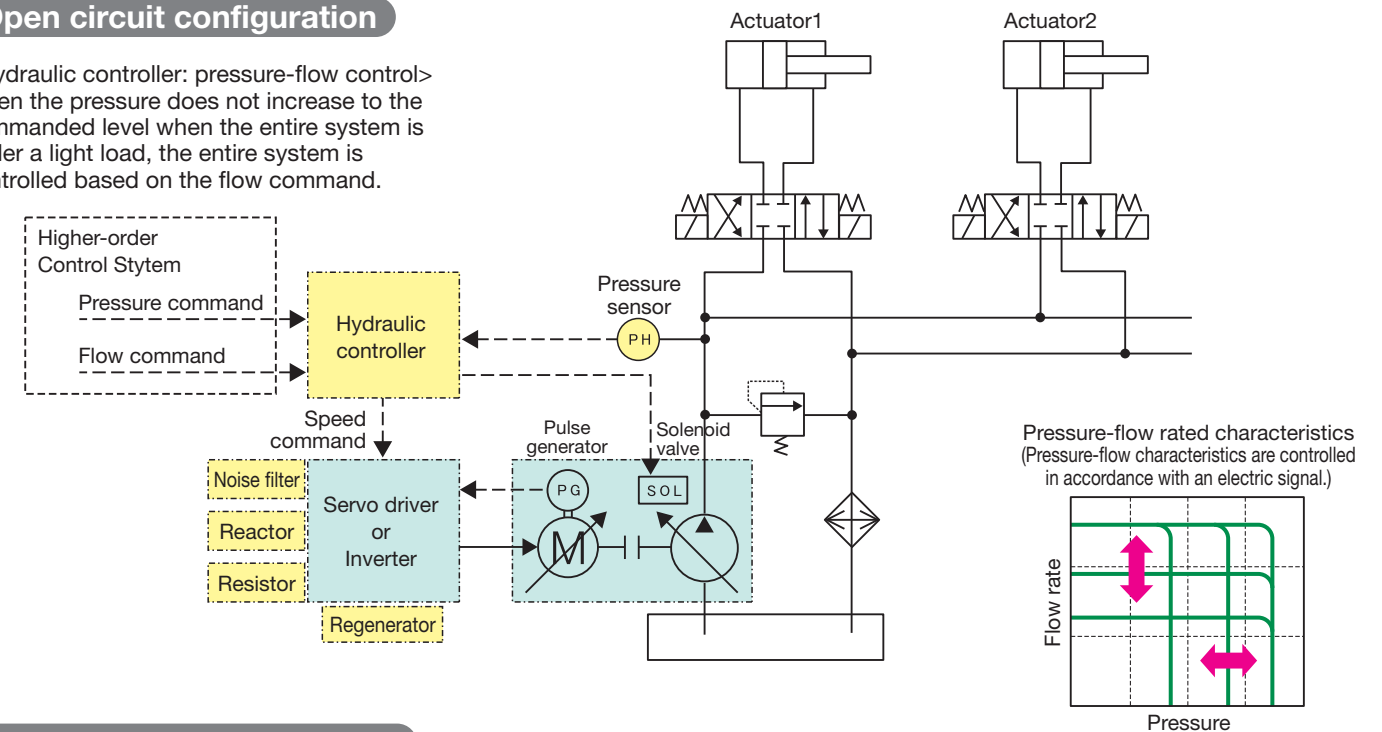

Closed circuit configuration

<Hydraulic controller: position-pressure control>
 Control mode is switched over to position control or pressure control by the signal from upper control section.

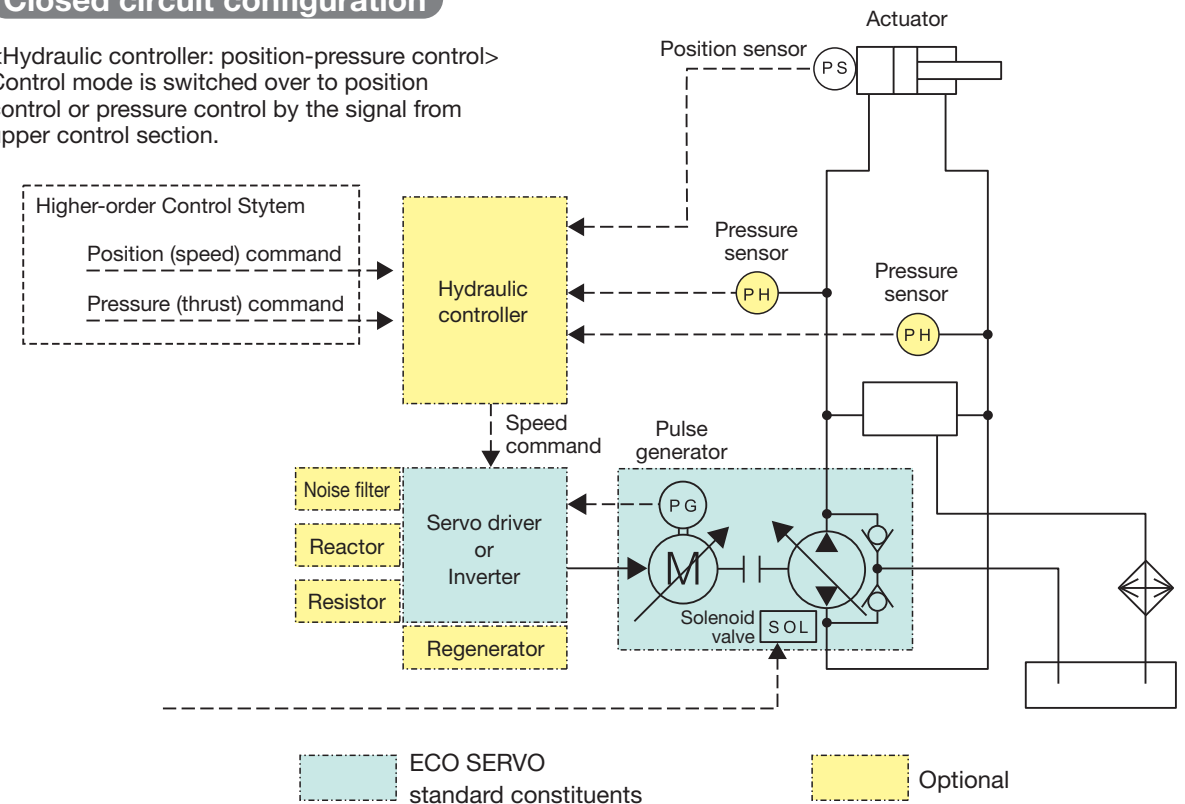

<ECO SERVO standard constituents>

- Pump (with displacement switchover solenoid valve), •Electric motor, •Inverter or servo driver, •Coupling, •Bracket with resilient support

<Optional>

- Hydraulic controller, •Noise filter, •DC reactor, •Braking resistor, •Power regenerator, •Cables and connectors for pulse generator, •Cables and connectors for servo driver, •Pressure sensor

Typical Examples of Open Circuit with Inverter Drive

- ◆ **Application examples:**
Press machine, forming machine, packing machine, etc.
(Control system: Speed control)

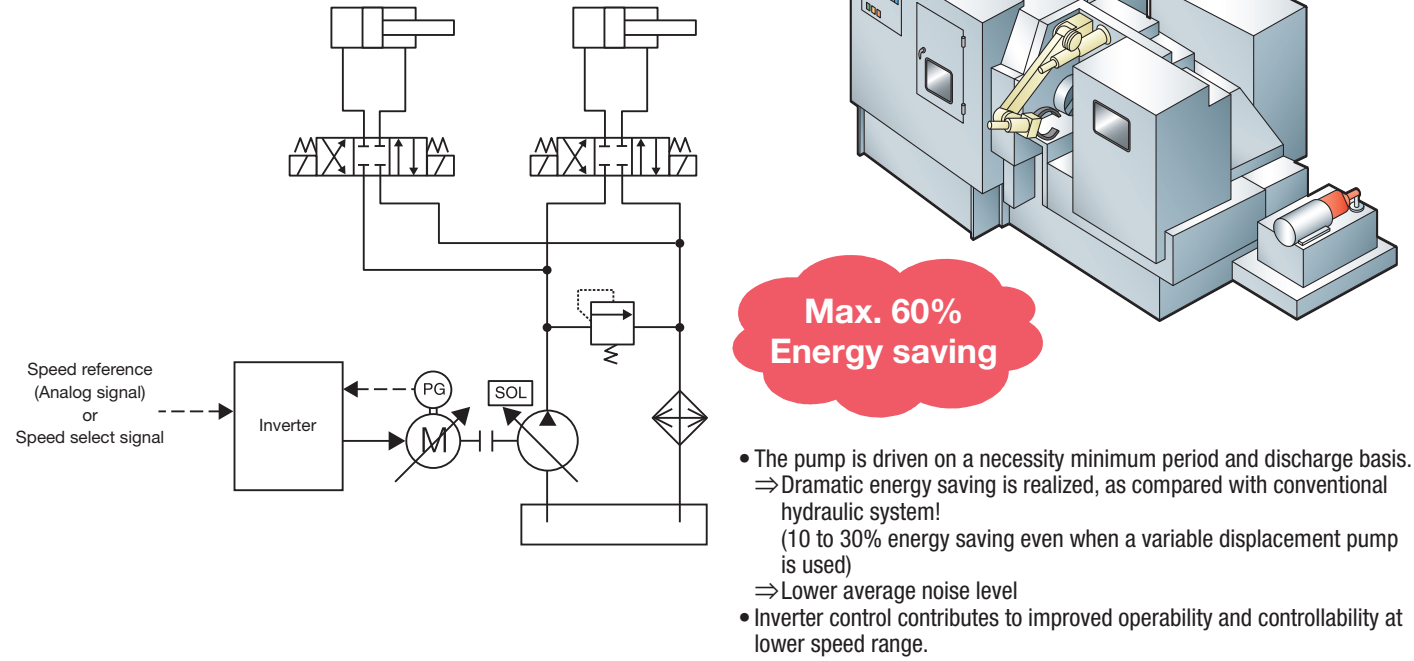

Typical Examples of Open Circuit with Servo Drive

- ◆ **Application examples:**
Injection molding machine, etc.
(Control system: Pressure control-speed control selectable)
- Improved functionality and performance, compared with pump control systems
- Response speed, energy saving and low noise level, comparable with those obtained from full electric control system.

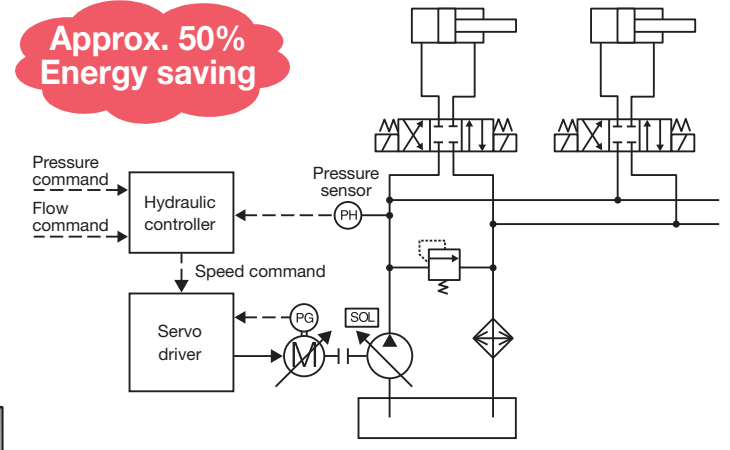
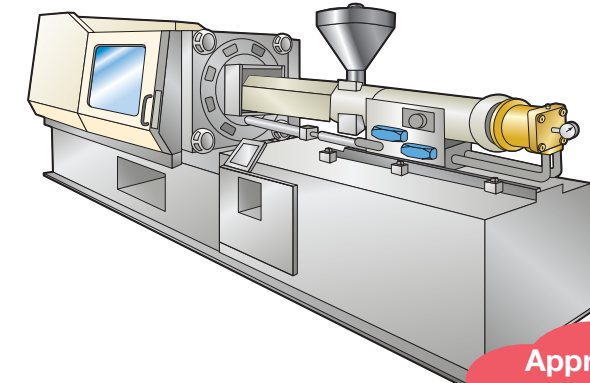

- ◆ **Application examples:**
Testing machine
(Control system: Pressure control, power regeneration)
- When the load is moving upward, energy consumption is decreased through reduction in pressure loss.
- When the load is moving downward, energy consumption is further decreased as the motion energy of the load is converted into electric power.

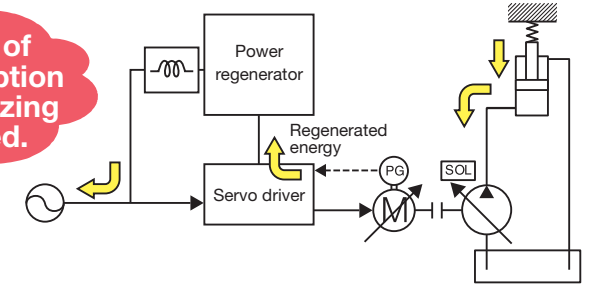

Inverter Drive

Servo Drive

Typical Examples of Closed Circuit with Inverter Drive

- ◆ **Application examples: Reclaimer**
(Control system: Speed control)
- **Hydraulic system renewal work**
[Conventional system] (pump control system)
 - Pilot piping is needed.
 [ECO SERVO]
 - No pilot piping is needed.
 - Improved repeatability and low-speed control precision
 - Easy maintenance

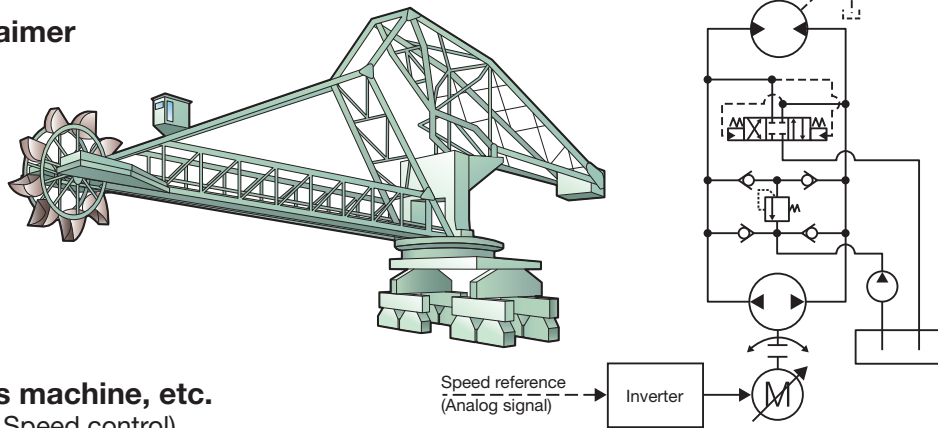

- ◆ **Application examples: Press machine, etc.**
(Control system: Position control, Speed control)
- **Energy saving effects on press machine**

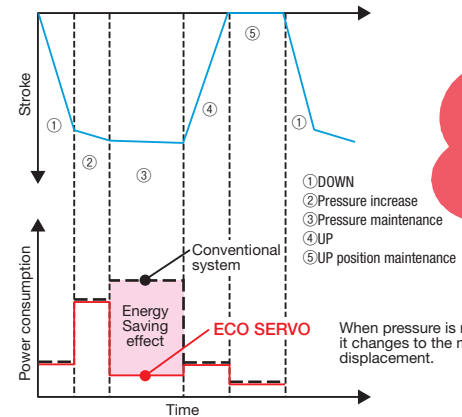
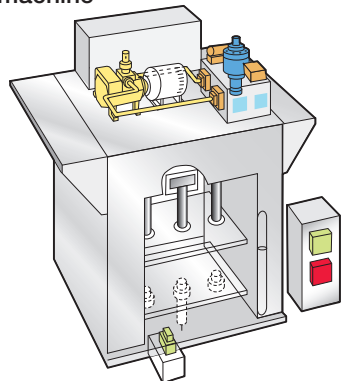

Closed circuit

Typical Examples of Closed Circuit with Servo Drive

- ◆ **Application examples: Press machine**
(Control system: Position control-pressure control selectable)
- Use of a two-step variable displacement pump leads to smaller electric motor size and energy saving.
- Highly accurate position control is readily achieved with a hydraulic controller!

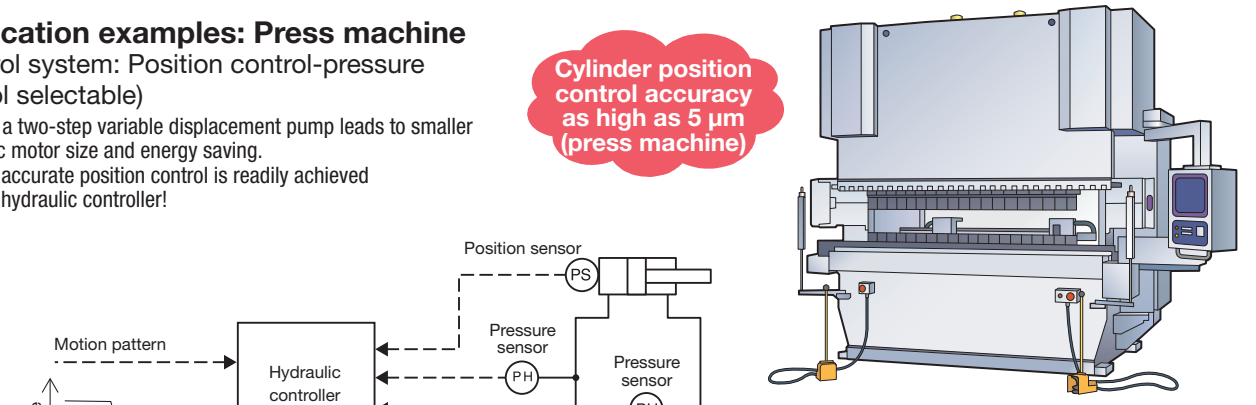

- ◆ **Application examples: Propeller pitch controller, etc.**
(Control system: Position control)
- Unlike servo-valve system, strict maintenance works of hydraulic fluid are not necessary.
- Since direction valves are unnecessary, the system is compact.

External Dimensions

Pump unit (for open circuit / inverter drive)

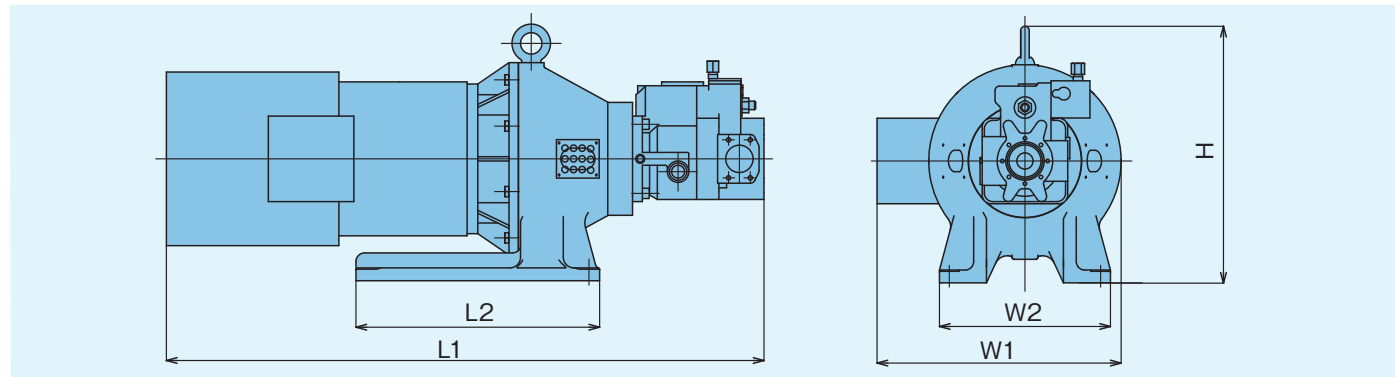

Type	Motor	L1 (mm)	L2 (mm)	W1 (mm)	W2 (mm)	H (mm)	Mass (kg)
KESP45-V**	30kW	1,320	570	571	400	600	395
KESP80-V**	37kW	1,360	570	571	400	600	410
KESP140-V**	55kW	1,660	660	653	550	710	625

Pump unit (for closed circuit / servo drive)

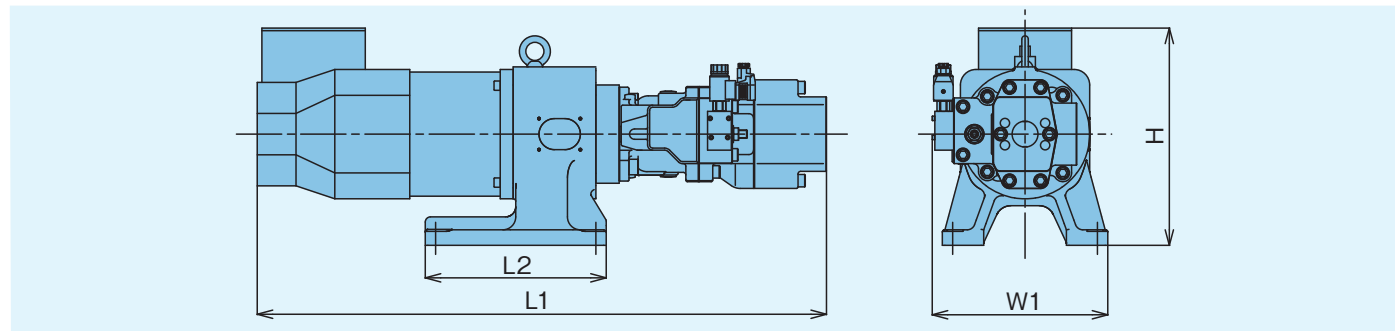

Type	Motor	L1 (mm)	L2 (mm)	W1 (mm)	H (mm)	Mass (kg)
KESP45C-S**	11kW	920	350	320	410	170
KESP80C-S**	15kW	1,080	350	320	410	200
KESP140C-S**	45kW	1,380	450	440	490	415
KESP200C-S**	55kW	1,560	500	460	580	550

Hydraulic controller KESC-**-** (optional)

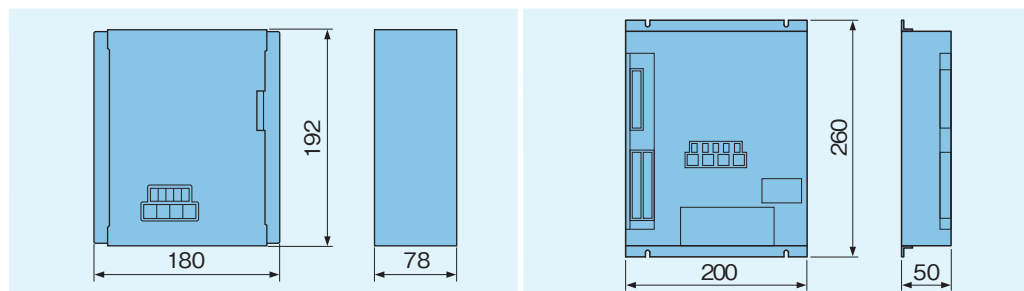

Item	KESC-40-10	KESC-31PQ-10
Power supply	DC24V	DC24V
Command-sensor input	Position signal (analog/digital) Pressure signal (analog) Flow signal (analog)	Pressure signal (analog) Flow signal (analog)

*1: For information about the external dimensions of the inverter and servo driver, contact Kawasaki Precision Machinery.

*2: For information about the detailed specification for the hydraulic controller, contact Kawasaki Precision Machinery.

Optional Equipment

A full lineup of optional equipment allows the users to build a diversity of systems.

Name of optional equipment	Typical applications	Selection practice and considerations
Hydraulic controller	This controller calculates a pump speed based on the position, speed and pressure commands, and outputs a speed command to a motor driver.	Employ the hydraulic controller when wanting to isolate the hydraulic control system from the upper control section and construct a self-contained control system within the hydraulic system. Two types of hydraulic controller are available—position-pressure controller and pressure-flow controller. Select either type that is suitable for the intended hydraulic system.
Noise filter	The noise filter can suppress the noise occurring from the motor driver.	Troubles deriving from electrical noise can be positively prevented through basic noise countermeasures including noise-immune wiring arrangement and grounding work when designing the control panel. If a noise-derived problem occurs, it is necessary to select noise-immune equipment that helps solve the problem.
DC reactor	The DC reactor helps improve the input power factor for the motor driver and suppress the input higher harmonic current.	Use a DC reactor when the power supply capacity is larger relative to the motor driver capacity or a measure against harmonic current is needed.
Braking resistor	When braking torque is necessary on the motor driver circuit, the braking resistor converts the energy from the load side into heat to provide a braking torque.	A braking resistor must be incorporated when load torque and the losses of the motor driver and motor are not enough to provide the necessary braking torque. If an over-voltage alarm occurs on the motor driver when the motor is decelerating, then a braking resistor must be installed or it is necessary to decrease braking torque.
Power regenerator	The regenerator converts the braking energy from the load side into electricity and feeds this electricity to the power supply system, so that energy saving effect is further enhanced.	An electric regenerative system will be useful when the entire hydraulic system is frequently shut down and the amount of recovered electric power is large. When an electric regenerative system is incorporated, a braking resistor is no more necessary.

*1: For information about selection of specific optional equipment models, contact Kawasaki Precision Machinery.

Operating precautions

1. Considerations about selection of electric motor capacity

To determine the capacity of the electric motor that is used in conjunction with the hydraulic pump, use the following formula:

$$\blacksquare \text{ Required torque (N}\cdot\text{m)} \quad T = \frac{q \cdot \Delta p}{2\pi \cdot \eta_m}$$

$$\blacksquare \text{ Output power (kW)} \quad N = \frac{2\pi \cdot T \cdot n}{60,000} = \frac{T \cdot n}{9,550}$$

$$= \frac{Q \cdot \Delta p}{60 \cdot \eta_t}$$

q	: Displacement [cm ³]
Δp	: Effective pressure [MPa]
η _m	: Pump machine efficiency
n	: Speed [min ⁻¹]
Q	: Output flow [L/min]
η _t	: Pump total efficiency

For the instantaneous max. torque and continuous rated torque with the intended electric motor, refer to the specification table in page 5.

For information about the displacement of pump that is capable of displacement switchover, refer to the field for the intended pump model in the table within page 5. The capacity of electric motor can be decreased through displacement switchover.

2. Measures against noise occurrence

When housing the motor driver in the control panel, and when installing the control panel, provide in advance basic noise control measures which include: [1] isolation of the control circuit from the main electrical power circuit, [2] reliable grounding work, [3] use of shielded cables for the control circuit, and [4] use of metal conduit for the main electrical power circuit.

3. Precautions for using the pump

There are precautions for using the hydraulic pumps, and which include the external drain piping work, kind of hydraulic fluid, and cautions for operating the pump. For more details, refer to the catalog or instruction manual dedicated to the axial piston pump (K3VR, K3VL, K7VG series) for general industrial machinery.